



**MANUAL DE INSTRUCCIONES**  
***INSTRUCTION MANUAL***  
**MODE D'EMPLOI**

*INFORMACIÓN DE SEGURIDAD*

This user documentation contains **WARNINGS**, **CAUTIONS** and **INFORMATION** on the safe use of the product. Refer to the definitions below.



### **WARNINGS**

**WARNINGS** indicates dangerous situations that, if not avoided, could result in death or serious injury. It is very important not to proceed until you fulfill and understand all the established conditions.



### **CAUTION**

**CAUTION** Indicates dangerous situations that, if not avoided, may cause minor or moderate injuries. It is very important not to proceed until you fulfill and understand all the established conditions.



### **INFORMATION**

**INFORMATION** indicates instructions which must be followed to avoid damage to your bike or other equipment.

## **READ CAREFULLY THE CONTENT OF THIS MANUAL**



FAILURE TO COMPLY WITH THE INSTRUCTIONS IN THIS MANUAL CAN RESULT IN AN INCORRECT OPERATION OF THE BICYCLE THAT MAY HAVE AS A CONSEQUENCE AN ACCIDENT OF SERIOUS PERSONAL INJURY

THE USE OF THE BICYCLE WILL BE LIMITED TO THE TYPE OF SERVICE INDICATED BY THE MANUFACTURER. IMPROPER USE OR DRIVING MAY ENDANGER ITS INTEGRITY OR THAT OF THIRD PARTIES ALWAYS USE AN APPROVED PROTECTIVE HELMET

WEAR SUITABLE CLOTHING FOR RIDING A BIKE

IN STRETCHES OF LOW VISIBILITY OR WITH INSUFFICIENT NATURAL ILLUMINATION USE LIGHTS AND REFLECTIVE BANDS

DO NOT EXCEED THE PERMISSIBLE TOTAL WEIGHT OF THE BIKE

THE MODIFICATION OF THE FRAME, SUSPENSION, ENGINE, BATTERY OR SOME OTHER COMPONENT, IN ADDITION TO THE HIGH RISK THAT CAUSES SAFETY, IT LEAVES THE WARRANTY OUT OF SERVICE

THE MECHANICAL OR ELECTRONIC HANDLING OF ANY COMPONENT OF THE BICYCLE WILL EXEMPT ANY RESPONSIBILITY TO JTG BIKES



# INDEX

1. General information	4
2. Bike parts	6
3. Technical characteristics of the bicycle	7
4. Adjustments, revision and maintenance	9
5. Screen and motor settings	17
6. Preparations for use	21
7. Maintenance program	23
8. User safety	25
9. Tips and recommendations	28
10. Battery charge	30
11. Manufacturer's guarantee	31
12. Declaration of conformity of the manufacturer	33

# 1. GENERAL INFORMATION

## MANUFACTURER INFORMATION

We wish to greet you and thank you for choosing the G2 GRUP brand e-mountainbike GEB21.

This User's Manual contains all the necessary information for the correct use of the bicycle and its maintenance. If you follow the instructions in this manual, you can use the vehicle safely and guarantee its reliability, obtaining the maximum performance from the bicycle.

Read this Manual carefully before getting on the bicycle, and keep it in a safe place for future reference. If you have any questions about it, ask your G2 GRUP distributor.

The parents or guardians responsible for minors who use the bicycle must pay special attention to the contents of this Manual as well as the use of the bicycle. The continuous evolution of the G2 GRUP bicycles to offer its customers a product with higher performance and the best materials, may involve a change in some of the components of the bicycle without prior notice to its Customers. However, the traceability of the bicycle and its original components is guaranteed by its serial number indicated on the manufacturer's plate.

For more information about our products, we provide you with our data:

Requirement	Content
Name and address of the manufacturer	<b>TECH PARTS G2 SL</b> 17162 BESCANÓ-Girona (Spain) Tel.: 0034 679 92 83 61 sales@g2grup.com www.g2grup.com
Technical service	<b>G2 BICYCLES</b> 17162 BESCANÓ-Girona (Spain) Tel.: 0034 679 92 83 61 sales@g2bicycles.com www.g2grup.com
Place and date of the EC declaration	BESCANÓ-Girona (Spain) 04/07/2018

## CONFORMITY WITH THE CE

This product complies with RD 339/2014 and the European Directive that are mentioned in the table through compliance with the corresponding harmonized standards. G2 GRUP has a copy of this declaration of compliance that is attached in this manual.

Directive	Title
2001/95/CE	Directive on general product safety



## INTERNATIONAL HARMONIZED STANDARDS

UNE - EN 15194 + A1:2012

UNE - EN ISO 4210 parts 1 - 9:2014 - 2015

## SIZE AND MAXIMUM WEIGHT AUTHORIZED

Model	Size	WHEEL	PMA (kg)
GEB21	M	27.5"	100
	L		100
	M	29"	100
	L		100

## 2. BIKE PARTS

1	Frame	21	Back brake
2	Front fork	22	Pneumatic
3	Swingarm	23	Rim
4	Suspension rod	24	Radio
5	Rear shock absorber	25	Bushing
6	Seat	26	Fastener
7	Seatpost	27	Electric motor
8	Seat block	28	Batery
9	Power meter	29	Screen
10	Handlebar	30	Charger
11	Brake lever		
12	Gear shift control		
13	Game direction		
14	Plate		
15	Connecting rod		
16	Pedal		
17	Cassette		
18	Chain		
19	Rear derailleur		
20	Front brake		



### 3. BIKE TECHNICAL CHARACTERISTICS



Nuevo diseño  
*New design*

Componentes de alta calidad  
*High quality components*

Servicio  
*Service*



<b>Brand</b> <b>Marca</b>	G2 GRUP	<b>Frame</b> <b>Chasis</b>	Aluminio / Aluminium	<b>Rims</b> <b>Llantas</b>	27,5" 29"
<b>Model</b> <b>Modelo</b>	GEB21	<b>Front suspension</b> <b>Suspensión delantera</b>	180 mm - Oil / Air Control	<b>Front tire</b> <b>Neumático delantero</b>	27,5" x 2.80 29" x 2.50
<b>Power</b> <b>Potencia</b>	250 W (Adjustable 9 s.)	<b>Shock absorber</b> <b>Amortiguador trasero</b>	180 mm - Oil / Air Control	<b>Rear tire</b> <b>Neumático trasero</b>	27,5" x 2.80 29" x 2.50
<b>Engine</b> <b>Motor</b>	Brushless 48 V	<b>Transmission</b> <b>Transmisión</b>	Por cadena / Chain	<b>Handlebar</b> <b>Manillar</b>	Variable section
<b>Battery</b> <b>Batería</b>	850 W	<b>Secondary transmission</b> <b>Transmisión secundaria</b>	11 V - 11/46	<b>Seat</b> <b>Sillín</b>	Comfort / Hight comfort
<b>Display</b> <b>Display</b>	Multifuntion	<b>Front brake</b> <b>Freno delantero</b>	Hydraulic - system 4 pistons	<b>Seatpost</b> <b>Tija sillín</b>	Telescópica/ Telescopic
<b>Charge time</b> <b>Tiempo carga</b>	5 - 6 H	<b>Rear brake</b> <b>Freno trasero</b>	Hydraulic - system 4 pistons	<b>Pedals</b> <b>Pedales</b>	Aluminio mixto / Mixed aluminium
<b>Range</b> <b>Autonomía</b>	150 Kmts	<b>Front brake disc</b> <b>Disco freno delantero</b>	Disc 203 mm	<b>Wheel base</b> <b>Distancia entre ejes</b>	1.210 mm
<b>Max. Speed</b> <b>Vel. Máxima</b>	25 Kmts / h	<b>Rear brake disc</b> <b>Disco freno trasero</b>	Disc 180 mm	<b>Weight</b> <b>Peso</b>	27 Kg



## 4. ADJUSTMENTS, REVISION AND MAINTENANCE

In order to avoid injuries, accidents, and optimize the physical effort in the use of the bicycle, it is very important that you strictly follow the indications that we detail in the points that we indicate below.

### SEAT HEIGHT ADJUSTMENT

The height of the seat will be obtained indirectly by a simple calculation.

With the clamping flange of the tight tube seat and the trim seat in a horizontal position. Measure the distance from the center of the seat to the center of the bottom bracket screw.

Multiply the measure obtained by the coefficient 0,885. The result will correspond to the maximum recommended height of the seat.



*It is very important for your safety that you check that the mark indicating the maximum height of the seatpost does not exceed the chassis housing. If this happens it is very possible that the size of the box is not appropriate for your height.*

### FIXING THE SEAT AND YOUR SEATPOST



*Make sure that both the clamping flange of the seatpost and the seat clamp to the seatpost are tight, and that there is no radial, axial or rotational movement of the seatpost or seat.*

### HANDLEBAR ADJUSTMENT

The measurement on the handlebar will be made on the axis of the handles.

The values indicated in the table are intended to adjust the handlebar in a comfortable position that prevents pain or injury:

Seat height	Difference in height with the handlebar
65 - 68 cm	5 - 6 cm
69 - 72 cm	6 - 7 cm
73 - 76 cm	7 - 8 cm
77 - 79 cm	8 - 9 cm
80 - 82 cm	9 - 10 cm

## HANDLEBAR ALIGNMENT WITH THE FRONT WHEEL

Check the absence of play in the union between the power and the handlebar, and the steering axle and the power, trying to move it with respect to the front wheel blocking the wheel with both legs.

Check that all screws are tightened with the tightening torques indicated in the table in this manual.

## FRONT SUSPENSION ADJUSTMENT

The front suspension, manufactured by JOTAGAS, is equipped with an inverted fork oil pneumatic, adjustable in load and preload, and with hydraulic expansion regulation.

### Preload

The adjustment of the fork preload is carried out by the rotary knob located on the upper part of the left side tube. Blue color control.

Turning the knob clockwise increases the preload of the suspension.

The preload of the front suspension allows to adjust the static travel of the front suspension under the weight of the user and to avoid the loss of efficiency of the suspension due to excess preload. The recommended value is between 12 and 30 mm.

Note that the preload must be readjusted according to the ground type and that in courses with uniform terrain a higher preload reduces the user's pedaling effort.

The fork is also equipped with a gas chamber in the damping system. The maximum load pressure must never exceed 13 bar. The value of this pressure affects the hardness of the suspension and will slightly modify the preload. We recommend a value between 4 and 8 bar.



*To determine the correct preload, it must be taken into account that in no case should the front suspension stop at its end of travel.*

### Hydraulic

The regulation of the hydraulics is located in the upper part of the right tube of the fork. Red color control.

Turning the knob clockwise decreases the speed of return of the suspension, closing the hydraulic passage.

## REAR SUSPENSION REGULATION

The rear suspension, is equipped with a swingarm and a central shock absorber pneumatic, adjustable in load and preload, and with hydraulic regulation.

### Preload

The regulation of the shock preload is made by combining the pressures of the upper chamber, of the main pressure and of the lower chamber, of negative pressure. Taking into account that the increase of the pressure in the upper chamber will increase the hardness of the shock absorber. And that the increase in pressure in the lower chamber increases the preload of the shock absorber.

The pressure variations of both chambers must always be combined. The recommended reference values are the following:

User weight (kg)	Upper chamber (bar)	Lower chamber (bar)
50	6,2	3,5
60	7,2	3,5
70	8,3	3,8
80	9,3	4,5
90	10,3	4,8
100	11,4	5,2



*To determine the correct pressure settings, it must be taken into account that in no case should the rear shock absorber stop at its end of travel.*

### Hydraulic

The regulation of the hydraulics is endowed with a double control, located in the upper part of the shock absorber.

The blue knob has three positions; open, medium and blocking. This command is of macro-regulation. The blocking position is only used when the user is driving through terrain without irregularities.

The red knob only acts in the intermediate position. Turning the knob clockwise decreases the speed of return of the suspension, closing the hydraulic passage.



*In order to determine the correct hydraulic settings, the type of terrain on which it circulates must be taken into account.*

## **TYPE OF TRANSMISSION**

The electric motor of the JEB19 bicycle is located on the bottom bracket axis. So it shares all the elements of the transmission with the action of the pedals.

The transmission of the bicycle is constituted by; the pedals (assisted by an electric motor of 250W), plate and cranks, Chain and a cassette of sprocket equipped with a change (rear derailleur).

## **QUICK VERIFICATION OF THE TRANSMISSION AND PEDALIER AXIS**

With a correct adjustment of the change, this will act with precision, without jumps and in absence of noises.

At least once a month, check that the sprocket and the chain are clean and well greased. All the links of the chain must pivot well, without jumps over the sprocket and without squeaks. Also, no link must be deformed or dented.

Lift the rear wheel and make it turn. If you hear a strange noise or the sprocket stop just drop them, they may need to be repaired or replaced.

Every three months inspect your pedals. Make sure that these are tight to the connecting cranks. Do not confuse the location of the pedals. The right pedal is marked on its axis with the letter R. Screw the axle clockwise and the left pedal in the opposite direction.

To check the absence of the bearings of the pedals, move the cranks in vertical and horizontal direction. In case of detecting movement, take the bicycle to your distributor for review.

Check the connecting crank every three months and check the tightening torque of the screws and the rigidity of the merge.

## **PLATE VERIFICATION ADJUSTMENT**

- Turn the plate until the connecting cranks are parallel to the seatpost.
- Put one hand on the crank and another on the seatpost; try to move the crank towards and against the seatpost, if it is loose this needs to be checked by your authorized dealer.

- If you turn the plate you notice that it is loose or if you hear a strange sound in the motor bearings; These will need to be checked by your authorized dealer.
- Clean the plate and inspect it for damage. If any tooth is twisted or worn, the plate should be replaced by your authorized dealer.

Check the chain every three months for any signs of wear. Each complete link of a chain measures one inch (25.4mm). If twelve links in the chain measure more than 30.8 cm, the chain must be replaced. The life of the chain is associated with the use made of the bicycle. With a good maintenance, the chain usually lasts between 1500 and 2500 km. In extreme service and with environments of dust, stones or mud, the life of the chain can be substantially reduced. To change the chain you need special tools and knowledge so you should go to your authorized dealer.

## **TRANSMISSION ADJUSTMENT**

For your safety. Do not attempt to make any adjustments to the elements of the transmission. The adjustment of the transmission set consisting of sprocket, chain, plate and pedals must be made by your authorized dealer, since it requires specific tools and knowledge.

## **TRANSMISSION LUBRICATION AND CLEANING**

Once a month, clean and lubricate the sprocket and the chain. Always put a cloth behind the chain to prevent oil from falling on the rest of the bicycle. Once lubricated the chain clean the excess oil with a dry cloth.

To clean the sprockets, use only commercial specific products to the cleaning of bicycle chains. If not indicated by the manufacturer, protect the swingarm and the frame of the possible projections of the degreasing agent that can damage the surface treatment of the frame and the swingarm. In the sprocket and change use a brush.

Once a year lubricate the bearings of the pedal, the mechanism of the automatic pedals and the part of the pedals that is screwed to the connecting cranks. Some bearings are sealed, not needing lubrication. Lubrication of the bearings requires specific tools and knowledge, and must be carried out by the authorized distributor.

In spite of not being recommended by G2 GRUP. In sports and competition, it is common to clean bicycles with water under pressure. In these cases the lubrication should be carried out after each wash. And always by an authorized dealer.

Note: the left (L) and right (R) pedal have a stamp stamped on the corner indicating which side they belong to.

Always use high performance lubricants with Teflon additives specific to bicycle transmissions, and compatible with the decorative elements of the frame and swingarm, which are usually indicated on the labels as compatible with carbon frames.

## **DIRECTION LUBRICATION**

Do not attempt to grease the steering bearings. The lubrication of the direction must be done by your authorized dealer, it requires specific tools and knowledge.

## **REAR CHANGE REGULATION**

This operation should only be carried out if you have adequate tools and the necessary knowledge and practice. Otherwise, go to an authorized dealer.

- Regulation of the speed change path: It has two adjustment screws for the inner and outer limits of the route. Turn the two screws so that the chain does not leave its axial path. The change roller is aligned with the smallest sprocket and the largest sprocket.
- Speed change adjustment: Place the gear change control in the second indication.
- Turn the adjusting screw of the cable tension until a perfect adjustment is achieved on the second sprocket.
- Check that the change acts correctly on all the cassette sprockets.

## **GEAR CHANGES USE**

To avoid any mechanical problem (chain or change damage, pedaling noise, etc.), follow these recommendations:

- Select the correct speed by changing just before the start of the climb or the obstacle.
- When you intend to change speed, keep pedaling normally but without forcing, by operating the shift lever until the chain is seated correctly on the sprocket and the selected plate.
- Avoid changing speed in full force, even if synchronized systems allow it in a hurry. It is preferable to overexert or get off the bike.

## TRANSMISSION ELEMENTS TIGHTENING PAIRS

Component	Par (Nm)
Front wheel axle nuts	8 - 10
Stem screw	8 - 10
Connecting rod screw	25 - 50
Pedals	33 - 55
Brake caliper bolt	8 - 10
Screw brake discs	10 - 12
Brake lever screw	2 - 4

The tightening of the other components requires specific tools and knowledge and must be carried out by your authorized distributor.

The indicated tightening torques are those that we recommend both in re-tightening and after dismantling. In this last case it is very important to clean and degrease the threads, and the screws.

## BRAKES ADJUSTMENT

The GEB21 bicycle is equipped with hydraulic brakes. The adjustment of the brakes must be done by your authorized dealer, since it requires specific tools and knowledge.



*Improper handling of the brakes by the user can cause an accident with serious physical consequences.*

## LOADING BATTERY OF THE ELECTRICAL TRACTION

1. Verify that the local network is compatible with the electrical characteristics of the charger.

Network voltage	AC 100 V - 240 V
Frequency	47 Hz - 63 Hz
Consumption	1,8 A

2. Remove the battery from its housing on the bicycle.
3. Insert the connector of the charger to the battery, and then the connector of the plug of the socket.

## BATTERY CHARGE SECURITY

The caring for the battery is vital not only for your own safety, but also for maximizing the life of the battery. Critical situations such as this fire or an explosion can occur if the recommended instructions are not followed.

- Make sure the charger connector is dry and securely connected to the battery connector.
- Carry out the load in ventilated premises. Do not cover the battery or charger while charging the battery, or near flammable components. The ambient temperature should not exceed 40 ° C.
- Keep the battery away from water to avoid short circuits.
- Only use the charger supplied with the battery.
- Do not manipulate or modify anything of the battery.
- Do not expose the battery near fire or extreme temperatures.
- Avoid hits or strong impacts.
- Once the battery has been charged, first remove the connector from the mains socket, and then the battery connector. It is not recommended that the charger connector be connected to the network when the charging process has finished.
- Stop the operation of the battery charge immediately in case of detecting the smell of burning, and contact your authorized dealer.
- The battery and charger should be stored out of the reach of children.
- To regulate the use of the electric bicycle with long distances, it is advisable to recharge the battery before each departure and to its maximum energy capacity.
- Occasional use: On short and continuous trips the battery should be charged at least once a week. If the bicycle is not used, it must be charged every 3 months.



*The manufacturer can not be held responsible for the damage that can be done to the battery when it is charged for misuse by the user.*



## 5. SCREEN AND ENGINE ADJUSTMENTS

### DISPLAY



Aluminum alloy  
*Aleación de aluminio*

Toughened glass  
*Vidrio Templado*

Black matte  
*Negro mate*



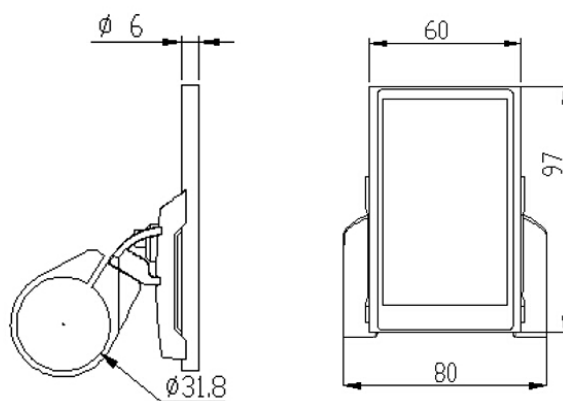

1	Battery indicator
2	Speed indicator
3	Pedal assistance
4	Km traveled
5	Upload speed
6	Slow down
7	Button on and off the display

### Actions by pressing and holding the button

5	Press and hold to turn on the display light
6	Press and hold for "walk"
6+7	Press and hold to delete Km Trip A y B

## BATTERY



Aluminum alloy  
*Aleación de aluminio*

Toughened glass  
*Vidrio Templado*

Black matte  
*Negro mate*





Battery charging method: PLUG-IN



Battery charging



Shock absorber

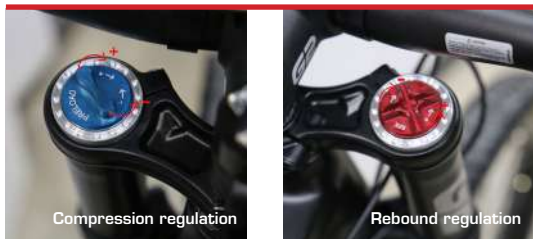

Suspension



Seat adjustment

## 6. PREPARATIONS FOR YOUR USE

Check the bicycle and its components before using it. Remember that if you detect a problem on your bike, in case you can not repair it, you have to take it to your authorized dealer.

Do not use the bicycle after detecting abnormal operation or at the slightest sign of failure.

### WHEELS

#### ALIGNMENT

Turn each wheel and watch the rim pass without jumping through the fork and swingarm, and that the brake discs do not push the brake pads. If the tire's rotation is not uniform, take your bicycle to your authorized dealer.

#### FIXING

For safer driving, the wheels of your bike must be firmly attached to the fork and swingarm. The front wheel is connected by two screws. The rear wheel is equipped with a tightening by eccentric tank.

#### INFLATION PRESSURE

Inflate the tires with the recommended air pressure on the side of the tires. Also take into account the weight of the cyclist. High pressure provides better performance on hard surfaces such as asphalt, while low pressures are better for off roads.

### BRAKES

This bicycle is equipped with hydraulically operated disc brakes on both wheels. If you detect a lack of efficiency in the brakes go to an authorized dealer.

The handle located on the right side of the handlebar activates the rear brake and the handle located on the left side of the handlebar actuates the front brake, unless the legislation of the country requires it in reverse.

Ensure proper operation of the front and rear brakes.

The brake discs can only be cleaned with water. Remove dirt and mud before using the bicycle.

In case of detecting scratches, cracks or deformations in the brake discs, consult your authorized dealer.

### MANILLAR Y POTENCIA

Make sure the power and handlebar are correctly positioned and tightened.

Carefully inspect the handlebar and power for signs of fatigue: scratches, cracks, dents, deformations or discolorations. If any part shows possible fatigue damage, replace it

before riding a bicycle. Also, check that the handlebar plugs are correctly positioned at the ends.

## **SEAT**

The seat must be positioned at the proper height for the cyclist's size and use. In addition, you should check that the seatpost and seat are correctly positioned and tightened.

The maximum height of the seatpost can only be placed without exceeding the horizontal limit mark.

## **SUSPENSIONS ADJUSTMENT**



Make sure that the suspension components are adjusted to your liking, and that no suspension element reaches its stop. The suspension affects the behavior of the bicycle, so a correct adjustment is very important. If the suspension is compressed so much that it blocks the fork, a loss of control may occur. For more information on adjusting the suspension, see the chapter "Adjusting, reviewing and maintaining your bicycle".

## 7. MAINTENANCE PROGRAM

<i>Before each use</i>	<i>Once a week</i>	<i>Once a month</i>	<i>Every 3 weeks</i>	<i>Once a year</i>
Check the inflation pressure and that it is adjusted to that indicated on the tire and / or terrain characteristics	Check that the screws of the suspension elements are tight	Check the adjustment of the bottom bracket and steering shaft bearings	Inspect the plate and cassette of sprocket	Change the oil in the suspensions
Check the alignment of the wheels, that there is no play on the reels and that the axle nuts are tight	Check that the suspension elements are free from scratches or oil leakage	Check the chain damage	Inspection of the pedals and cranks	Lubricate the motor bearings
Check the effectiveness of your brakes, that the touch is not soft and that the travel of the levers does not stop with the handles. Check that there are no brake fluid leaks	Check the uniform tension of the spokes	Check the condition of the brake pads and the existence of play in the brake fluid gas mechanisms		Lubricate the bearings of the reels
Check that the suspension settings are adequate		Check that the change is not damaged and its functionality at all speeds		Oil steering kit bearings
Check that the height of the seat is adequate for your measurements and that the locking flange is tight	Clean the bicycle	Check that the seatpost and the clamping flange are not damaged or distorted		Oil steering kit bearings
Check that the height of the handlebar is appropriate for the height of the seat		Check if the maximum battery charge level reaches the maximum nominal value		
Check the handlebar fixation and power		Check engine parameters		
Check that the frame and swingarm are not damaged				

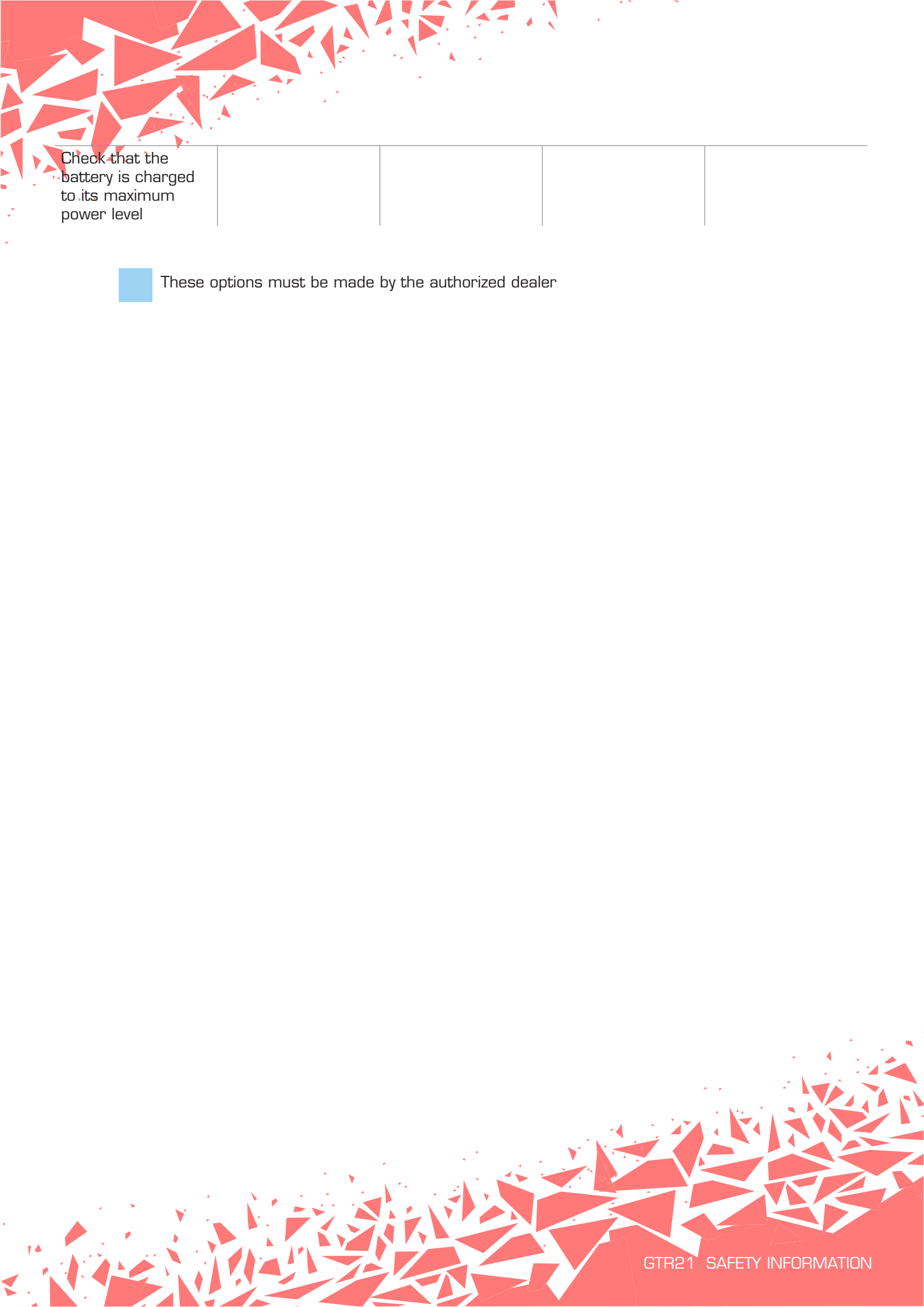
A decorative red geometric pattern consisting of various sized triangles and polygons, located at the top and bottom of the page.

Check that the battery is charged to its maximum power level				
--	--	--	--	--



These options must be made by the authorized dealer



## 8. USER SECURITY

### HELMET USE



Always use the helmet. Make sure that it complies with CE regulations or equivalent regulations.

Always use specific protective gloves for the use of bicycles or mountain bikes. In sporting use or in competitions use specific gloves for mountain biking or motocross. We recommend the use of specific clothing and footwear for use on mountain bikes. In advanced sports use and in competition with strong descents, we recommend the use of chest, back, elbows and knee protectors.

### SUSPENSIONS ADJUSTMENT

Adjust the suspensions according to the conditions of the route. An incorrect adjustment can cause you to strain your pedaling and even accident.

### KNOW THE LOCAL REGULATIONS ON THE CIRCULATION OF BIKES

The JEB19 bicycle is designed for the practice of mountain biking, but it can be used on public roads. Most states have specific regulations for cyclists. In cycling clubs, federations, town halls or the Department of Transportation (or equivalent) in your area, they should be able to give you information about it.

Some of the most important rules on public roads are:

- Use appropriate manual signals.
- When traveling with more cyclists, form a single line.
- Go on the right side of the road, never in the opposite direction.
- Wait for the unexpected and roll with a defensive attitude. A cyclist is difficult to see, and many drivers are not used to recognizing the rights of cyclists.

### DO NOT PERFORM UNSAFE ACTIONS WITH THE BICYCLE

In the mountains, use the bicycle according to your level of skill. Progress appropriately in improving your driving level.

Many bicycle accidents on public roads could be avoided using common sense:

- Do not drive "without hands": the smallest imperfection on the road can cause a sudden vibration or rotation of the front wheel.

- Do not drive with objects hanging from the handlebars or other part of the frame: these could be inserted in the spokes or cause a sudden turn of the handlebar, losing control of the bicycle.
- Do not drive under the influence of alcohol or drugs that may cause drowsiness. The bicycle requires a good coordination of movements and the cyclist must always be alert of what happens around.
- Do not take anyone on the bike. This bicycle is not designed to carry the additional weight of a second passenger. In addition, the extra weight makes the bicycle more difficult to perform the turning maneuver and the suspensions work inefficiently.

## **BIKE SPORTS USE**

The GEB21 bicycle is specially designed to travel on the mountain. Practice this sport with safety and total respect for the environment. Do not drive off trails if doing it, violates any local or state regulations.

Minimize the risk of accident. Always wear specific clothing and protections for the practice of this sport and minimize the risk of accidents by adapting the speed and jumps to your driving level.

Progress appropriately in improving your driving level.

After an eventual fall or mishap, verify that the bicycle is in the correct state of use.

## **BIKE COMPETITION USE**

Always respect the rules established by the organization.

Do not make any modification to the bicycle that may cause the breach of the technical regulation of its category. Doing so may affect the coverage of the manufacturer's warranty.

Do not clean the bicycle with pressurized water. If you clean the bicycle with water under pressure, keep in mind that the water can overcome the barrier of the sealing elements, penetrate into mechanical elements, and that their presence can cause breakdowns.

## **TOOLS AND SPARE PARTS**

We recommend you always carry a puncture repair kit, a spare camera and some detachable ones.

In the market, specific multi-purpose tools for bicycles are commercialized, which can be of great help to solve some mechanical impact, if your mechanical knowledge and experience are adequate.

## 9. TIPS AND RECOMMENDATIONS

### PROTECTION OF THE BICYCLE AGAINST BLOWS

Park your bicycle always in areas where it is out of the way of vehicles in circulation and make sure it has a stable position, so that it can not fall. Do not lean the bicycle on the change (rear derailleur) as this could be damaged or dirty. Avoid any fall on the bike, as this can damage the handlebar or seat among other things.

### PREVENTING THE FRONT SUSPENSION FROM IMPACTING THE FRAME



In advanced sporting and competition use of the bicycle, possible falls may occur which could cause the impact of the suspension tubes with the frame. If this happens, it is very important to verify if after the fall the frame has been damaged. In this case the use of the bicycle must be abandoned and a technical service must be attended.

### FALLS



In advanced sporting and competition use, eventual falls may occur which could cause the impact of the frame and / or rocker against rocks, trees, ramps, stakes and other elements that can cause structural damage.

They can also cause damage to the pedals, gearbox, handlebars, brakes and wheels. Do not resume the gear without having made a quick and effective inspection of the integrity of these elements. Restart the progress verifying its correct functionality.

In all cases, if damage or functional deficiencies are detected, the use of the bicycle must be abandoned and a technical service must be attended.

### DO NOT MODIFY THE COMPONENTS

The modification of any part of the bicycle, including frame, fork and other components, can reduce the safety of your bicycle.

Changing the fork of your bicycle can influence the direction of the bicycle or create unexpected stresses:

- If you wish to change the fork of a bicycle, consult your authorized dealer for the various compatibility options.
- Any modification of frame, fork or components means that the bicycle no longer meets our specifications and, therefore, the bicycle's warranty will be canceled.



*Never repair or modify the frame assembly. Also do not perform sanding, drilling, filling or disassembling of redundant retention devices, or any other. An incorrect modification can cause you to lose control and fall.*

## 10. BATTERY CHARGE

The decrease in the maximum energy capacity stored in a battery is a consequence of the aging of the battery due to the number and typology of the recharge cycles and in no case is it a manufacturing defect.

Batteries are NOT considered consumables subject to wear.

If you stop using the bicycle for a prolonged period. Charge it at least every 4 weeks.

Do not remove the battery from the bicycle unless you use it temporarily or infrequently.

The ambient temperature for the storage of the battery should be between 15 and 30°C. The temperature in summer can slightly affect the battery, so a cool, dry place is recommended.

Carry out recharging of the battery in a air out place away from combustibles.

The components that are processed as a guarantee are the battery itself and the BMS protection circuit.

The battery has a useful life of between 500 and 600 cycles of loading and unloading when it is performed optimally, its depth of discharge (DOD) does not exceed 80%, and its state of charge (SOC) reaches 100% of its maximum energy capacity.

The life cycle in service of a battery is determined by the frequency of use, by the load cycles, by the load and service temperature and by the DOD.

The autonomy is very proportional to the level of the land: It is not the same a flat land as a land with climbs. In this last case the battery provides more power and autonomy suffers.

To ensure maximum autonomy, it is advisable to drive at a moderate and continuous



speed, since the battery performance increases.

Always use the charger supplied with your model.

*Any manipulation in the battery, charger or electrical circuit can cause a short circuit and cause injuries and / or burns.*

## 11. MANUFACTURER'S GUARANTEE

A legal guarantee is established through the Seller / Distributor and in accordance with the General Law for the Defense of Consumers and Users according to the Guarantees Directive in the Sale of Consumer Goods RDL 1/2007:

### WARRANTY CONDITIONS

G2 GRUP guarantees its bicycles against any manufacturing or assembly defect, covering the replacement of the defective parts or repairing them under the following conditions:

- Warranty period on bicycles: 24 months against manufacturing defects and assembly on mechanical elements, from the date of purchase shown on the invoice, on the purchase ticket or on the delivery note.
- Warranty period for electrical components: 12 months against manufacturing and assembly defects, from the date of sale of G2 GRUP to the authorized distributor.
- In case of replacement, a new warranty period for the new product is not started. The warranty period will correspond to the pending term of the guarantee of origin of the substituted product.
- Guarantee period for components repaired by an accredited workshop: 6 months against manufacturing and assembly defects, from the day that appears on the delivery note of the repair.
- The consumer must inform the seller of his / her lack of conformity of the alleged incident, immediately and / or exceptionally within a maximum period of one month from when he / she became aware of it.
- Except proof otherwise, it is presumed that the delivery of the product to the point of sale, official distributor, is correct, so the warranty claim for new product stored is 3 months maximum after delivery.
- The guarantee is limited to the original purchaser and is not transferable to the following and future buyers without prior notification and explicit acceptance of G2 GRUP.
- The inclusion of a bicycle or part in the warranty conditions is subject in last place to the decision of the G2 GRUP Technical Service.
- The warranty period will be suspended for the duration of the repairs and in the case of replacement, it will be automatically renewed with respect to the affected element.
- All warranty claims for G2 GRUP parts must be made through the authorized dealer that made the sale.

*NOTE: All unmarked G2 GRUP components must be compatible with the bicycle and covered by the original manufacturer's warranty.*

- The warranty does not cover in any case the replacement of parts whose wear is due to normal use of the bicycle. These parts are called consumables: Tires, chain, plates, sprocket, brake pads, discs, fuses, light bulbs, etc ...
- The warranty does not cover damages resulting from improper use of the product, or cracks due to impact or fatigue, bends, dents, thread passes, etc. Especially if the product could be used in competition, jumps or any other type of extreme piloting.

### **ADDITIONAL CONDITIONS**

- The guarantee does not cover in any case:
  - Damages that are attributed to errors or failures in the interpretation of tips in the manual.
  - Faults and damages attributable to accidents, impacts, improper use, repairs carried out incorrectly, lack of maintenance and care.
  - Modifications of the bicycle by someone external to an official G2 GRUP service.
  - Do not pass mandatory reviews at the point where you purchased your vehicle or at an official G2 GRUP distributor
  - In case of agents or external elements (natural catastrophes, floods, fire, theft, etc.)
- G2 GRUP is not responsible for incidents or collateral damage caused to third parties.

*The non-acceptance of these conditions will lead to G2 GRUP not being responsible or assuming any responsibility for warranty compliance. If you have any questions, contact your usual official distributor or G2 GRUP.*

### **PROCESSING OF THE APPLICATION FOR WARRANTY COVERAGE**

The procedures must always be carried out through the authorized distributor.

## 12. DECLARATION OF CONFORMITY OF THE MANUFACTURER

Manufacturer: **TECH PARTS G2, S.L.**

Address: **17162 BESCANÓ-Girona (Spain)**

It declares under its own responsibility, that the bicycle:

Name: **Pedaling bicycle assisted e-montanbike (EPAC).**

Brand: **G2 GRUP**

Model: **GEB21**

Serial no. (Fixed part): **GEB21 \* \* \* \***

Year of production: **2020**

Subject of this declaration, it complies with the requirements of Royal Decree 2822/1998, Directive 32001/95/EC and Commission Decision 2011/786/EU, on the commercialization of bicycles.

The following harmonized standards have been used in its design:

- UNE - EN 15194 + A1:2012
- UNE - EN ISO 4210 parts 1 - 9:2014 - 2015

The control system of the production of the bicycle is guaranteed by the quality procedures that are applied in all the operations that are associated with its manufacture.







**READY TO WIN!**

[www.g2grup.com](http://www.g2grup.com)

**CONTACT**

SPARE PARTS DEPARTMENT  
[parts@g2grup.com](mailto:parts@g2grup.com)

SALES DEPARTMENT  
[sales@g2grup.com](mailto:sales@g2grup.com)